

Launch Control 2
Technical Manual
V2013.08_EN

1	General	4
	Validity	4
	Safety	4
	Target Group	4
	Layout	4
	DT Swiss Manual Concept	4
	How to Use this Manual	5
	Cross References	5
	Warranty (Europe)	5
	Limited Equipment Warranty USA	6
1.1	General Maintenance Information	7
	Cleaning	7
	Tools	7
	Environmental Protection	7
	Disclaimer	7
2	Description	8
2.1	Spring: ABS (Auto Balancing Spring System)	8
2.2	Damping: Launch Control	8
3	Installation	9
3.1	Shortening the Steerer	9
	Shortening a Carbon Steerer	10
	Shortening a Aluminium Steerer	12
3.2	Installation of the Fork	13
	Install the Crown Race	14
	Install the Fork and the Stem	14
	Install the Stem and the Spacers	14
	Adjust the Bearing Play of the Headset	14
	Install the Stem	15
3.3	Installation of the Brake	16
3.4	Installation of the front Wheel	17
	Usage of a RWS thru Axle	17
	Usage of a quick release	17
	Collision Test	17
4	Operation and Setting	18
4.1	Setting the Air pressure	18

	Recommended Air pressure	18
	Setting the SAG (Negative-Travel)	19
	Set the Air pressure	19
4.2	Set the Damping	20
	Activating	21
	Deactivating	21
5	Service and Care	22
<hr/>		
5.1	Care	22
5.2	Service Intervals	22
5.3	Small Service	23
	Release the Air	24
	Dismount the Control Elements	24
	Disassembly of the Fork	25
	Dismount the Main Sealing	28
	Dismount the ABS Unit	29
	Check and clean the Parts	29
	Mount the ABS Unit	30
	Mount the Main Sealings	31
	Mount the lower Unit	33
	Mount the control Elements	36
6	Trouble Shooting	38
<hr/>		
	Bedding-In Time	38
	After a Crash	38
	Bushing Clearance	38
	Trouble Shooting	38

1 General

Validity

This manual describes the component shown on the front page and the footer. It is valid for the construction level of the component on the 2013-08-14. Deviations are possible and all items are subject to technical changes.

Safety

The safety instructions are classified as follows:

NOTE

...characterizes danger for goods.



CAUTION

...characterizes danger with a high risk, which causes mayhem if it is not being avoided.



DANGER

...characterizes immediate danger with a high risk, which causes death or mayhem if it is not being avoided.

Target Group

This manual is intended for the end user and dealers.

For experienced users, it offers the possibility to carry out small maintenance works on their own. If there are any doubts concerning the own skills, there should be contacted a DT Swiss service center.

Warranty will expire if works are not done properly.

Layout

The cover page and the footing are providing information about the type of product and manual as well as the version of the manual.

The backside provides a list of the DT Swiss service centers. A list of all DT Swiss service centers can be found at www.dtswiss.com.

This manual is intended for printing as a A5 booklet. Only print this manual if electrical usage is not possible.

DT Swiss Manual Concept

The DT Swiss manuals are splitted into the following types of manuals:

- User Manual
Information for the end user of how to install and use the component.
- Technical Manual
Detailed information for the end user and the dealer of how to maintain the component, spare parts and technical data.
- Service Sheet
Short instructions strictly for the service centers to solve current issues.
- Service Center Manual
Information strictly for the service centers about all service works, disassembling, checking and reassembling of the component.

How to Use this Manual

The steps described in this manual must be carried out in the order they are shown. If steps are ignored or executed in a wrong order, the function of the component cannot be guaranteed.

Instructions are beginning with the table «Preparatory Steps» and ending with the table «Closing Steps». The instructions in these tables must be carried out.

Moving parts, threads, o-rings and sealings must be greased before assembling.

Cross References

In order to simplify the use of this manual, some text is edited as hypertext. Whenever the text is formatted blue and underlined, you can click on the text. After clicking you will be automatically redirected to the target of the link.

Example: Click here: [chap. 1, page 4](#) to jump to the beginning of this chapter.

Warranty (Europe)

In addition to the general guarantee required by law, DT Swiss AG based in Biel/Switzerland, provides a guarantee for 24 months from the date of purchase in accordance with European Directive 99/44/EC. DT Swiss AG shall reject any liability for both indirect damage caused by accidents and consequential damage.

Any contradictory or extended national rights of the purchaser are not affected by this warranty. Place of performance and jurisdiction is Biel/Switzerland. Swiss law shall apply.

Submit any warranty claims to your retailer or a DT Swiss service center. Any defects recognised by DT Swiss AG as a warranty claim will be repaired or replaced by a DT Swiss service center.

Warranty and guarantee claims can only be made by the original purchaser with a valid sales receipt.

There shall be no claim under the guarantee for:

- Normal wear and tear caused by use of the components
- Incorrect assembly
- Incorrect or non-existent maintenance
- Incorrectly completed repairs
- Use of unsuitable products
- Modification of components
- Incorrect use or misuse
- Carelessness
- Leasing, commercial use or use in competitions
- Damage caused by accidents
- Delivery and transport damage
- Modification, defacing or removal of the serial number

Limited Equipment Warranty USA

DT Swiss LTD makes every effort to assure that its product meets high quality and durability standards and warrants to the original retail consumer/purchaser of our product that each product is free from defects in materials and workmanship as follows:

2 YEAR LIMITED WARRANTY ON THIS DT SWISS PRODUCT. This warranty does not apply to defects due directly or indirectly to misuse, abuse, negligence or accidents, repairs or alterations outside our facilities or to a lack of maintenance.

DT SWISS LTD LIMITS ALL IMPLIED WARRANTIES TO THE PERIOD OF TWO YEARS FROM THE DATE OF INITIAL PURCHASE AT RETAIL. EXCEPT AS STATED HEREIN, ANY IMPLIED WARRANTIES OF MERCHANTABILITY AND FITNESS ARE EXCLUDED. SOME STATES MAY NOT ALLOW LIMITATIONS ON HOW LONG THE IMPLIED WARRANTY LASTS, SO THE ABOVE LIMITATION MAY NOT APPLY TO YOU. DT SWISS LTD SHALL IN NO EVENT BE LIABLE FOR DEATH, INJURIES TO PEOPLE OR PROPERTY OR FOR INCIDENTAL, CONTINGENT, SPECIAL OR CONSEQUENTIAL DAMAGES ARISING FROM THE USE OF OUR PRODUCTS. SOME STATES MAY NOT ALLOW THE EXCLUSION OR LIMITATION OF INCIDENTAL OR CONSEQUENTIAL DAMAGES, SO THE ABOVE LIMITATION OR EXCLUSION MAY NOT APPLY TO YOU.

To take advantage of this warranty, the product or part must be returned for examination, postage prepaid, to the dealer where you bought the product or to a DT Swiss service center. Proof of purchase date and an explanation of the complaint must accompany the product. If our inspection discloses a defect, DT Swiss will either repair or replace the product or refund the purchase price, if we cannot readily and quickly provide a repair or replacement. DT Swiss will return repaired product or replacement at DT Swiss expense, but if it is determined there is no defect, or that the defect resulted from causes not within the scope of this warranty, then the user must bear the cost of shipping. This warranty gives you specific legal rights, and you may also have other rights which vary from state to state. Legal venue and place of performance is Biel (Switzerland). Swiss law shall apply. Subject to technical changes. Please keep the user manual and warranty for future use.

1.1 General Maintenance Information

Cleaning

For an optimal result of the maintenance works, every component that will be disassembled must be cleaned. There may only be used cleaners which do not damage the components. Especially the cleaning of o-rings and sealings requires mild cleaners. Always consider the instructions of the respective cleaner.

DT Swiss recommends the following cleaners:

- Motorex Rex
- Motorex Swissclean
- Motorex OPAL 2400, OPAL 3000, OPAL 5000

For external cleaning may be used soap water or similar mild cleaners.

Tools

To ensure a damage-free mounting and dismounting of the components, only the tools which are mentioned in this manual must be used. The usage of differing tools is up to the user. If components are being damaged by the usage of differing tools, the user is liable.

Environmental Protection

Whenever possible, waste has to be avoided. Waste, especially carbon, lubricants, cleaners and any other fluids must be disposed in an environmentally compatible manner.

Only print this manual, if electrical usage is not possible.

Disclaimer

The operations described in this manual should only be done by professionals. The user is liable for any damage or consequential damage which is caused by wrong maintained or wrong installed components. If you have doubts, please contact a DT Swiss service center.

2 Description

2.1 Spring: ABS (Auto Balancing Spring System)

DT Swiss forks with ABS spring technology are using a positive and a negative air spring. While adjusting the air pressure in the positive air chamber, the air pressure in the negative air chamber adjusts automatically. The air pressure in the positive and negative air chamber is always in an optimal ratio to the weight of the rider.

2.2 Damping: Launch Control

DT Swiss forks with Launch Control damping technology are equipped with an externally adjustable low speed rebound and compression damping. The high speed compression damping is preset and not adjustable.

The Launch Control function is an assistance for climbing where the rebound damping circuit will be closed to a pre-defined level. The fork cannot rebound completely and stays in lowered position until the Launch Control function gets deactivated.

3 Installation



DANGER

Danger due to exceeding or falling below the given torque!

Especially for carbon parts, the exceeding or the falling below the given torques may lead to faulty mechanical connections.

- Use torque wrenches with a appropriate adjustment range.
- Consider the torque values of each component. The lowest values are decisive, but it may not be fallen below the minimum values given by DT Swiss.

3.1 Shortening the Steerer

The length of the steerer essentially depends on the headset and the stem. It is mandatory to consult the instruction manual of the headset and the stem.

NOTE: When the headset and/or the stem will be exchanged, the new installation height can have an effect on the length of the steerer.

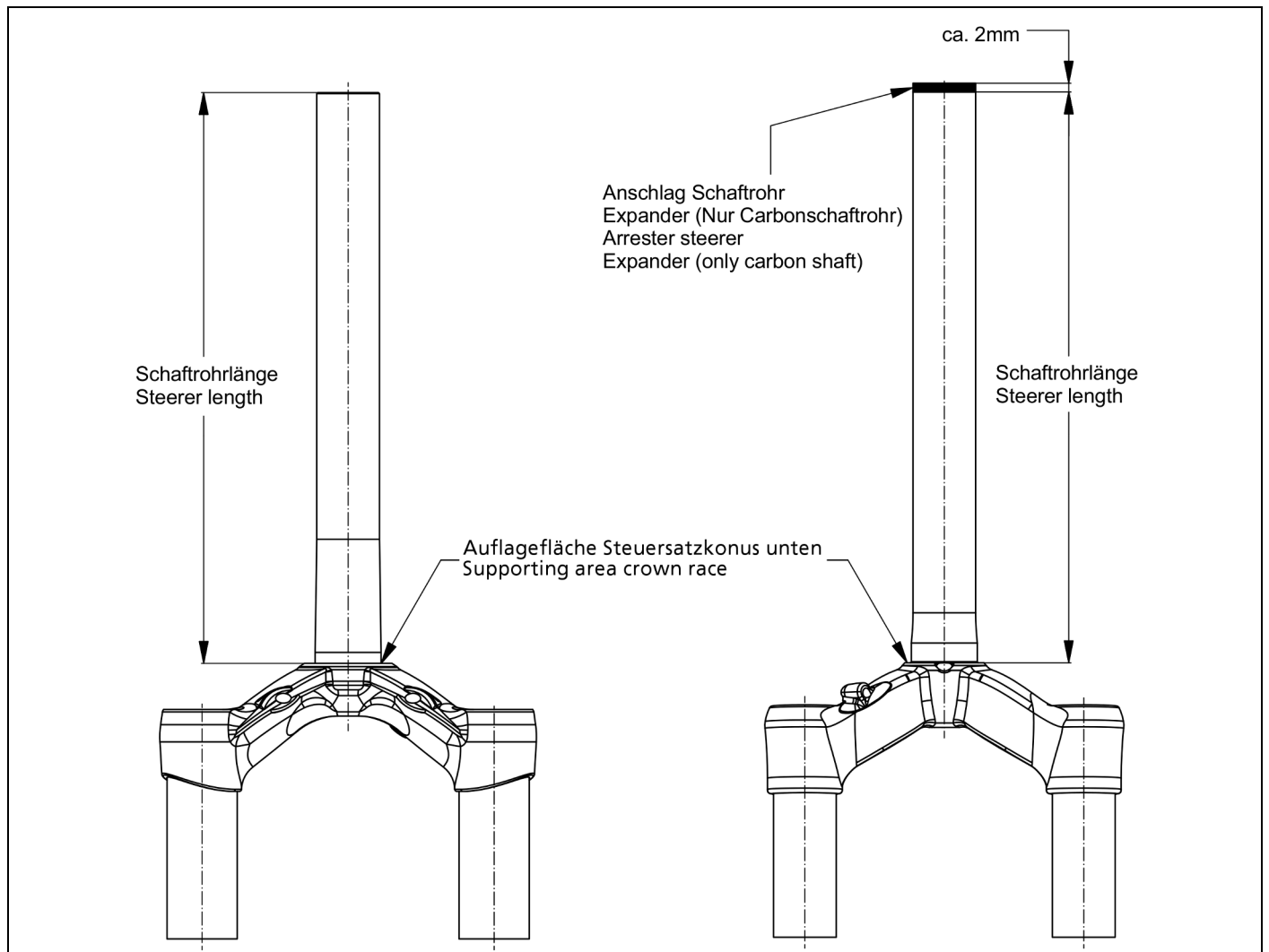

figure 3-1: Steerer

Preparatory Steps

Link

1. Dismount the fork from the bike.
2. Dismount the crown race off the old fork.
3. Measure the length of the old fork's steerer.
Ensure to measure the length from the support of the crown race to the end of the steerer.
4. Transfer the measured value to the new steerer.
5. Ensure, that the remaining clamping surface on the steerer complies the total height of the stem including a 5 mm spacer on top of the stem.

Shortening a Carbon Steerer

**DANGER****Risk of injuries when carrying out works with carbon!**

Take measures to protect yourself, especially your eyes, your skin and your respiratory tract before starting shortening the carbon steerer.

- Wear protective goggles.
- Wear protective gloves.
- Wear a respirator mask.

**DANGER****Risk of injury when using a star nut in combination with a carbon steerer!**

There must be no star nut used in combination with a carbon steerer.

- Only use the original DT Swiss steerer expander.
- The DT Swiss steerer expander must be mounted at every time.

The original DT Swiss steerer expander extends the lengths of the steerer about 2 mm.

Required Material	Specification	Amount
steerer expander		1
protective goggles	-	1
protective gloves	-	1 pair
respiration mask	-	1
adhesive tape	-	as required
handsaw	new saw blade for metal with min. 24 teeth per inch	1
sandpaper	grain min. 400	as required
cleaner	Motorex Swissclean 2300	as required

1. Put adhesive tape around the steerer in the place the steerer needs to be cut. This prevents the carbon fibers to fringe.



2. Cut the steerer to the desired length. Use a saw guide for cutting a carbon steerer!

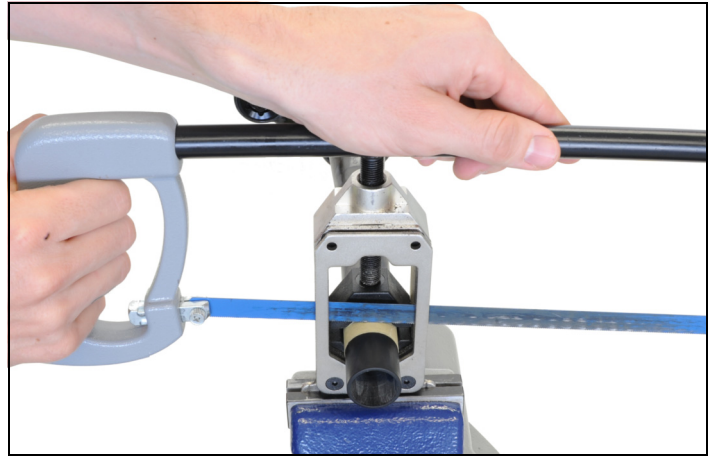

3. Carefully remove the adhesive tape from the steerer completely. Do not use aggressive cleaners to move remaining adhesive.

4. Grind the cutting edges on the inside and the outside of the steerer using sand paper. The carbon fibres on the cutting edge must not fringe.

5. Check the inner surface of the steerer for dirt and clean it if necessary.



6. Slide the steerer expander into the steerer until the upper part of the expander contacts the upper part of the steerer. Align the slotted bushing backwards.



7. Hold the expander and tighten the screw that fast, that the expander does not turn itself using a 6 mm Allen key. The maximum torque of 7 Nm must not be exceeded.



Shortening a Aluminium Steerer

Required Material	Specification	Amount
star nut	for 1 1/8" steerers	1
pipe cutter	-	1
file	-	1

1. Cut the steerer to the desired length. DT Swiss recommends to use a pipe cutter.
2. Deburr the steerer on the inside and on the outside using a file.
3. Drive the start nut into the steerer using a suitable tool.

Closing Steps	Link
Install the fork.	see following

3.2 Installation of the Fork

Preparatory Steps

[Link](#)

Read the instructions of the manufacturer of the stem.



DANGER

Danger due to incorrect installation of the fork!

- Only use compatible headsets.
DT Swiss forks either have a straight steerer with a diameter of 28.6 mm (1 1/8") or a tapered steerer with a diameter of 39.82 mm (1.5") at the bottom and 28.6 mm (1 1/8") at the top. Only use a headset which is compatible with your steerer diameter.
- Only use crown race reducers of the respective headset manufacturer.
- DT Swiss forks are built for a stem clamp without thread. Do not add any holes or threading, or make any kind of technical alternations to the fork.
- The steerer or the crown must not be damaged when assembling or using the DT Swiss fork. Special attention must be paid when fitting the headset crown race to the base of the steerer tube. The parts mounted on the fork should have no sharp edges.
- Do not use cotter style stems.
- The flange of the discontinuous clamp area of the stem must be at least 7mm high (see following figure).

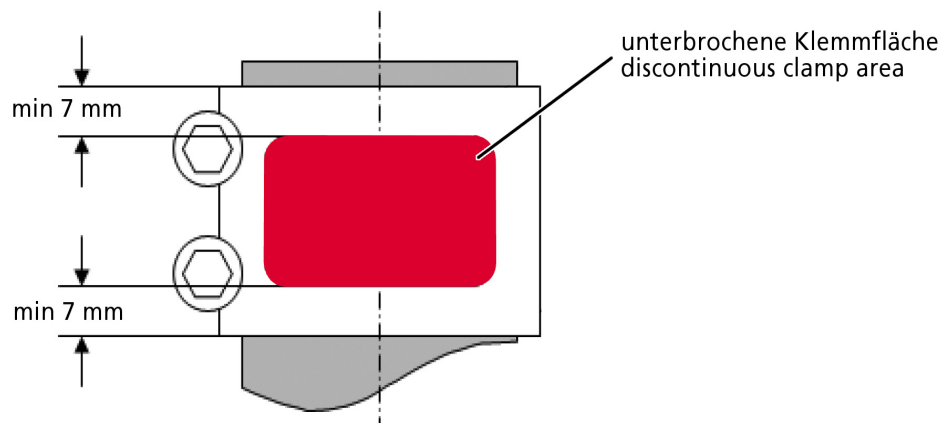

DANGER

Danger due to incorrect installation of the headset!

- The max. torque given by the manufacturer of the headset must not be exceeded.
- The DT Swiss steerer expander must be installed when a carbon steerer is used.
- Stem and headset must be installed in accordance with the instructions of the respective manufacturer.
- The adjusting screw of the headset is intended for adjusting the play of the headset. The screw is not intended for fixing!
- The crown race must not have sharp edges. These edges causes scratches to the steerer and shortens the lifetime of the fork or induces a breakage of the steerer.
- The fork must not be damaged while installing. Damages shortens the lifetime of the fork and can cause a breakage.
- If you are using a carbon steerer, only use stems which are released for usage in combination with carbon steerers.



DANGER

Danger due to incorrect installation of the headset!

For a faultless function, the following instructions must be followed:

- The spacers between headset and stem must be within the following limits:
 - minimum height: 5 mm
 - maximum height: 30 mm
- There must be a spacer on top of the stem with a height of 5 mm. This ensures that the stem is contacting the steerer with its entire surface.
- Ensure that the distance between the upper edge of the spacer and the steerer is big enough. Otherwise the play of the headset cannot be adjusted correctly. DT Swiss recommends a distance of 2 - 3 mm.

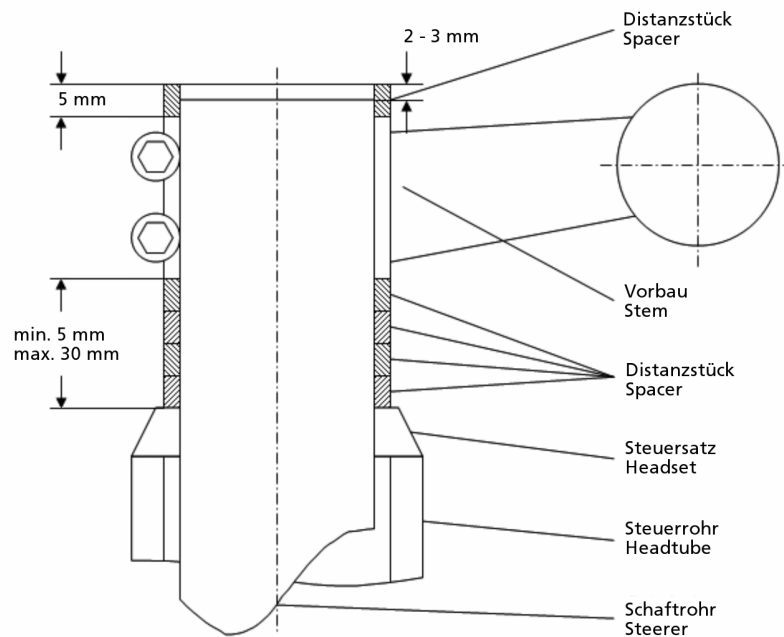

Install the Crown Race

1. Aluminium steerer: Apply a thin layer of grease onto the contact area of steerer and crown race. DT Swiss recommends Motorex Langzeitfett 2000.
Carbon steerer: Apply a thin layer of DT Swiss Carbon fitting lubricant.
2. Install the crown race in accordance with the instructions of the manufacturer.

Install the Fork and the Stem

1. Install the fork to the frame.
2. Ensure that the headset crown race and the compliant headset are fitted together properly.
3. Install the upper part of the headset in accordance with the instructions of the manufacturer.

Install the Stem and the Spacers

1. Add the spacers onto the steerer to set the desired height of the stem.
2. Carbon steerer: Apply a thin layer of DT Swiss Carbon fitting lubricant onto the contact area of the stem and the steerer.
3. Slide the stem onto the steerer. Do not tighten the fixing screws.
4. Add the spacer to the top of the stem.
Note the restrictions regarding the height of the spacers between stem and headset (see above).

Adjust the Bearing Play of the Headset

Adjust the bearing play in accordance with the instructions of the manufacturer.

Install the Stem

1. Align the stem and tighten the fixing screws in accordance with the instructions of the manufacturer. Consider the max. torque for carbon steerers!
2. In case the manufacturer of the stem does not specify specific torques for carbon steerers, proceed as follows:
 - a) Tighten the fixing screws with a torque of 4 Nm using a torque wrench.
 - b) Check if the stem is fitting securely on the steerer by jamming the front wheel between your legs and trying to twist the handlebar.
 - c) If this is not the case, enhance the torque in steps of 0.5 Nm and alternately tighten the fastening screw until the stem cannot be twisted anymore.
 - Do not exceed the maximum torque mentioned by the stem-manufacturer.
 - The steerer expander delivered with the fork has to be mounted during these operations.

Closing Steps	Link
Install the brake.	chap.3.3, p.16
Inflate the fork.	chap.4.1, p.18

3.3 Installation of the Brake

Preparatory Steps	Link
not required	
Fork-Model	Max. brake disc diameter
DT Swiss XRC	185 mm
DT Swiss XRM	210 mm
DT Swiss XMM	
DT Swiss XM	
DT Swiss EX	210 mm

i All DT Swiss Forks from 2009 on are equipped with Post Mount (PM) brake mounting standard for 160 mm. For usage of a brake discs with a bigger diameter than 160 mm, a appropriate adapter is needed.

1. Install the brake lever in accordance to the instructions of the manufacturer.
2. Install the brake pipe like shown in the picture.
Do not affix the brake pipe to the crown. Scratch areas must be protected by a suitable sticker.

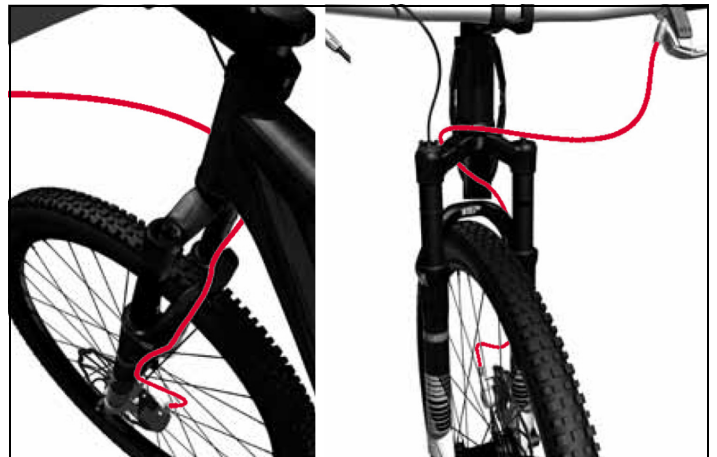

3. Install the brake caliper.
4. Screw in the fixing screws and tighten them with a torque of min. 6 Nm and max. of 10 Nm.
 - The max. torque must not exceed the specifications of the manufacturer.
 - The length of the thread must be min. 8 mm and max. 10 mm.

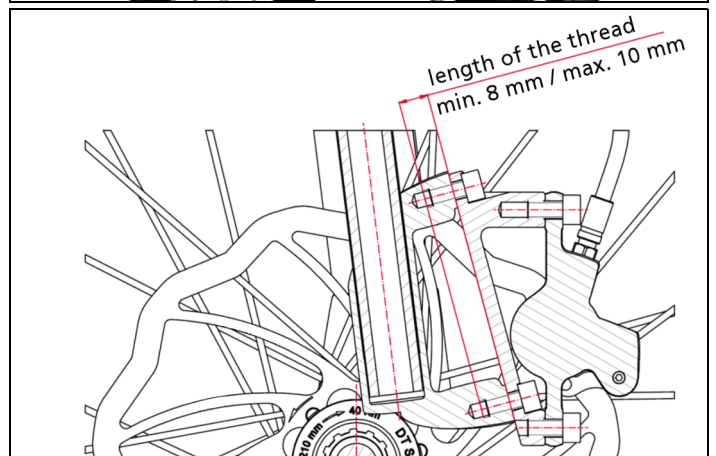

5. When using disc brakes without Center Lock adapter or disc brakes with a spider arm construction, a collision test must be made between the front wheel with mounted disc brake and the fork.
6. Install the brake in according to the instructions of the manufacturer.

Closing Steps	Link
Install the front wheel and perform a braking test.	see following

3.4 Installation of the front Wheel

Preparatory Steps

not required

Link

see following



DANGER

Risk of injury due to collision of the tire with parts of the fork!

A collision test must be performed after the front wheel was installed!

Usage of a RWS thru Axle

1. Remove the RWS from the fork.
2. Grease the RWS and its thread.
3. Put the front wheel into the dropout of the fork.
4. Slide the RWS through the right dropout of the fork, until the axle hits the thread in the left dropout.
5. Screw the RWS into the thread clockwise.
6. The lever of the RWS touches the fork lower during the last turns. When the lever touches the lower, lift the lever (1), turn the lever anti clockwise while lifted (2), release it (3) and continue fastening.
7. Repeat steps until the RWS is tightened.
8. Tighten the RWS with a min. torque of 15 Nm.



Usage of a quick release

Install the front wheel in accordance with the instructions of the manufacturer of the quick release.

Collision Test

1. Inflate the used tire to the max. pressure.
The max. pressure is given by either the tire or the rim. Decisive is the lower pressure of both components.
2. Release the air from the fork completely. Compress the fork completely.
3. Check, if the tire touches any part of the fork while it is fully compressed. Is this the case, the tire or the wheel must not be used!
4. If necessary, reduce the tire pressure to the desired operating pressure.

Closing Steps

Check the correct installation of the fork and function of the brake.

Link

4 Operation and Setting

4.1 Setting the Air pressure

Recommended Air pressure

The following air pressures are only reference values. The air pressure should be set to your personal preferences and to the correct SAG.

Rider's Weight [lbs / kg]	EXM 150, EXC 150 Recommended Air Pressure [psi / bar]
88 / 40	54 / 3.7
99 / 45	58 / 4.0
110 / 50	62 / 4.3
121 / 55	68 / 4.7
132 / 60	73 / 5.0
143 / 65	77 / 5.3
154 / 70	81 / 5.6
165 / 75	86 / 5.9
176 / 80	90 / 6.2
187 / 85	96 / 6.6
198 / 90	100 / 6.9
210 / 95	104 / 7.2
220 / 100	109 / 7.5
232 / 105	113 / 7.8
245 / 110	117 / 8.1
 max. air pressure [lbs / kg]	174 / 12

Setting the SAG (Negative-Travel)

The SAG is the amount of travel of which the fork will be compressed by the weight of the rider with full equipment. If the SAG is adjusted correctly, the front wheel can follow the ground during the ride better.

Riding Style	SAG-Value
Cross Country / Race	15% of the travel
Marathon / Tour	20% of the travel
All Mountain / Enduro	25% of the travel

To set the SAG, you should use the help of a second person.

1. Deactivate the Launch Control function by pulling the red wheel.
2. Push the o-ring on the right stanchion to the bottom, until it touches the main sealing.
3. Sit on the bike with full equipment (backpack, helmet, shoes...).
4. Sit on the bike as you would sit during the ride.
 - The fork goes down because of your own weight.
 - Avoid impact loads.
5. Get off your bike and measure the distance between o-ring and main sealing.
 - This measurement is called SAG.
 - The SAG should be between 15% and 25% of the full travel and can be adjusted depending on the riding style and use.
6. Set the air pressure if necessary (see following). Repeat steps above until the correct SAG is set.

Set the Air pressure

In all DT Swiss fork models, the air spring is located in the left stanchion. By adjusting the air pressure, the spring rate will be affected. The higher the air pressure, the harder the spring.

The air chamber is filled with a small amount of lubricating oil. Make sure that the valve is upwards during inflation or deflation.

Adjustment is possible by changing the air pressure. Adjusting the air pressure to the weight of the rider can slightly change the total length of the fork.

NOTE

Do not use the fork while the shock pump is mounted. This may cause the shock pump to touch the frame and the thread of the valve will break off.

Only use a suitable shock pump to adjust the air pressure. We suggest to use the DT Swiss shock pump.

1. Position the fork resp. the bicycle that the valve on the left upper stanchion is pointing upwards.
2. Remove the valve cap from the valve housing.
3. Mount a suitable shock pump on to the valve housing.
4. Adjust the air pressure by in- or deflating.
 - Check, if the correct SAG is set (see above).
5. Screw the valve cap on to the valve housing.

4.2 Set the Damping

The correct setting of the damping requires some patience, but the full potential of the fork can only be attained, if the setting is perfect.

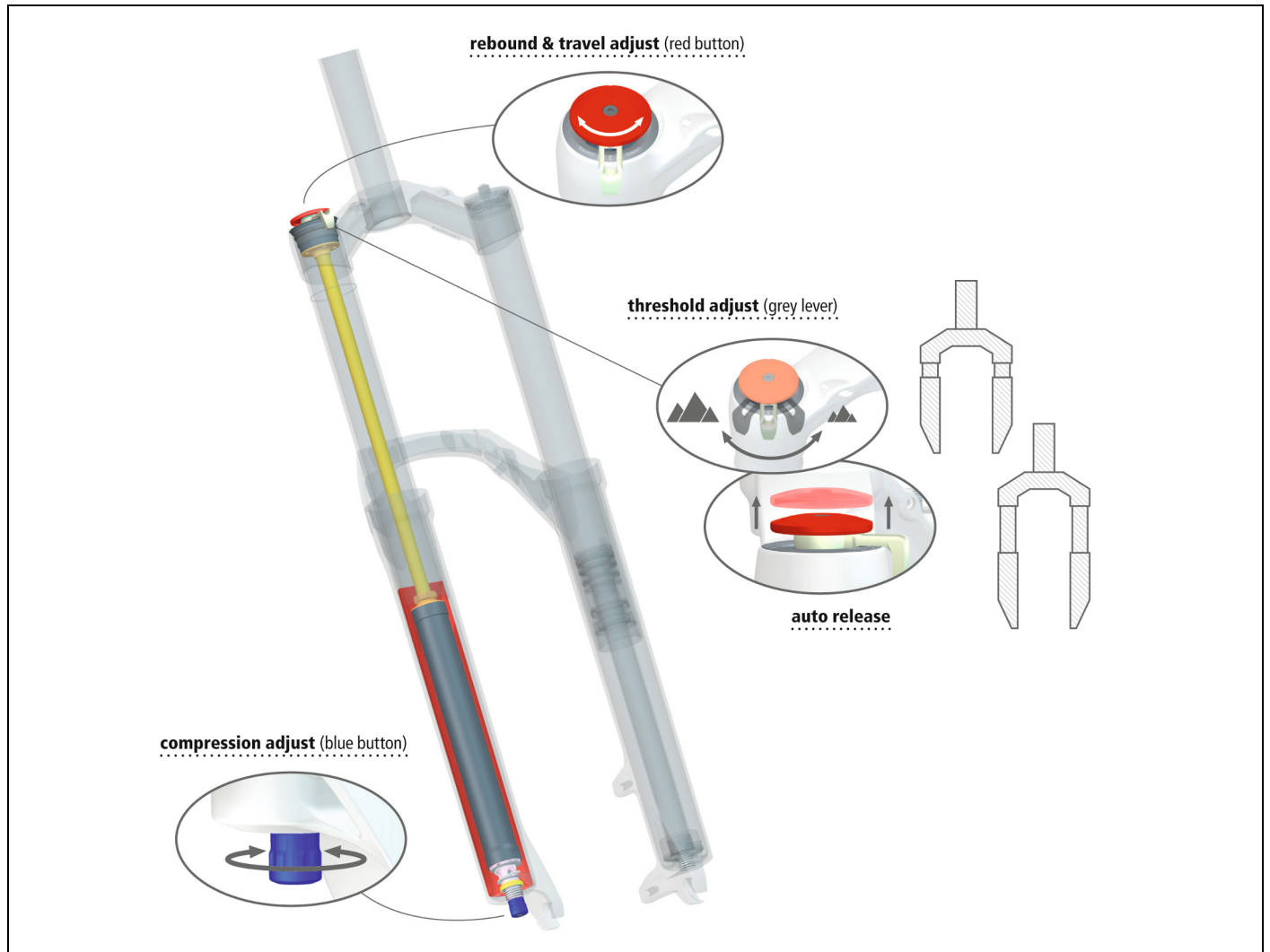

figure 4-1: Launch Control Damping

4.2.1 Rebound

The rebound controls the speed of the decompression movement.

To adjust the rebound damping, turn the red wheel (see [fig.4-1, p.20](#)) on top of the right stanchion.

- Turn clockwise to increase the rebound damping.
- Turn anti-clockwise to decrease the rebound damping.

If the rebound damping is too low, the front wheel decompresses too fast and loses the contact to the ground. If the rebound damping is too high, the front wheel can't follow fast impacts and the suspension hardens. The aim of setting the rebound damping is to achieve the best setting possible, which meets the requirements of the terrain best. Rough, fast downhills requires a low rebound damping, while flowy downhills without big hits requires a higher damping.

4.2.2 Compression

The compression controls the sensibility of the fork. Turn the blue adjuster knob (see [fig.4-1, p.20](#)) at the bottom end of the right stanchion.

- Turning clockwise increases the compression damping.
- Turning anti-clockwise decreases the compression damping.

The compression controls the sensibility of the fork. If the compression damping is fully opened, the sensibility of the fork is at its maximum. At the same time, a fully opened compression damping has the effect of negative influences from pedaling and more compression while riding steps in descents. Increasing the compression damping reduces these effects.

As well as the rebound, the setting of the compression damping depends on the terrain and the personal riding style. Fast, rough downhill requires a low compression damping. Slow, technical downhill requires a higher compression damping.

4.2.3 Launch Control



If the compression is turned to maximum and the threshold adjuster is in pos 1, it may have an influence to the Launch Control function. In this case decrease the low speed compression by turning the blue adjuster knob at the bottom end of the right stanchion or increase the release force of the Launch Control function by turning the nickel-plated adjuster lever clockwise.

Activating

Press down the red adjuster knob on the right stanchion completely and compress the fork. After strongly compressing the fork, the fork will rebound to a pre-defined level.

Deactivating



DANGER

Risk of injury when deactivating the Launch Control function manually!

The fork can rebound very fast, when deactivating the Launch Control function manually. The head of the rider must not be above the stem or the handlebar.

- Adjustment of the release force may not be done when the bike is in motion!

The Launch Control function can be deactivated manually or automatically.

The force needed to deactivate the Launch Control can be adjusted by turning the grey lever on the top of the right stanchion.

Clockwise to get the force higher, counterclockwise to get it lower.

- Manually: Pull out the red adjuster knob on the top of the right stanchion. The fork expands completely.
- Automatically: Through a shock from the ground (e.g. riding over obstacles) the Launch Control function will be deactivated automatically. The release force to deactivate the Launch Control function can be adjusted using the nickel-plated adjuster lever (Threshold Adjuster).

5 Service and Care

5.1 Care

To ensure a long product life, follow the instructions below:

- Clean the fork with a damp cloth. Remove dirt between stanchion/lower unit.
- Never use aggressive cleaners that damage rubber materials (main seals)!
- Never use high pressure cleaners. Water and dirt can get into the system and damage it!
- Remove all visible, dried dirt from the area of the main seals. This will prevent dirt from getting into the fork.
- It is not necessary to grease the main seals. To get a good lubrication of the main seals, regularly turn your bike or fork upside down.
- After cleaning, lubricate the sliding surface of the remote lever on the handlebar.

5.2 Service Intervals



If service intervals are not respected, any warranty claims can be denied.

Action	Interval
Big service by a DT Swiss service center	annual or after 200 operating hours*
Small service (see following)	50 operating hours*
Check the fork for damages and faultless function	before and after each ride
Check proper fixation	before and after each ride
Check the air pressure	before each ride
Clean with a soft cloth and a suitable cleaner, especially in the area of the main seals Do not use high pressure cleaners and aggressive cleaners!	after each ride

*If you use your bike in extreme conditions, you will have to service your components sooner.

5.3 Small Service

This manual only describes a small service. Further service works will be executed by a DT Swiss service center.

A small service should be carried out in the following cases:

- bad performance
- the fork is losing air
- after rides in extreme conditions
- after 50 operating hours
- after a crash to check the parts



DANGER

Danger to life due to wrong maintenance!

Incorrect maintenance or assembly can lead to unpredictable errors!

- Maintenance and assembly may only be done by a skilled professional.
- In case of any doubt, contact a DT Swiss service center.



DANGER

Risk of injury due to high air pressure!

Air with high pressure can escape suddenly while dismounting the fork!

- Always release the air before starting any works.

Preparatory Steps		Link
Clean the fork.		
Check all functions of the fork.		
Required Material	Specification	Amount
fork oil	DT Swiss Lube Fluid	1 Bottle à 100 ml
fork oil	DT Swiss Fork Oil	2 Bottles à 100 ml
Degreaser	Motorex Swissclean	as required
main seal kit Ø32 mm	contains 2 wipers, 2 foam rings, 2 spring rings	as required
special tool for wiper Ø32 mm		1

Release the Air

1. Unscrew the valve cap.
2. Release the air completely.



Dismount the Control Elements

1. Unscrew the compression adjuster knob using a 20.5 mm Allen key.
2. Remove the rebound adjuster knob using a 2 mm Allen key.

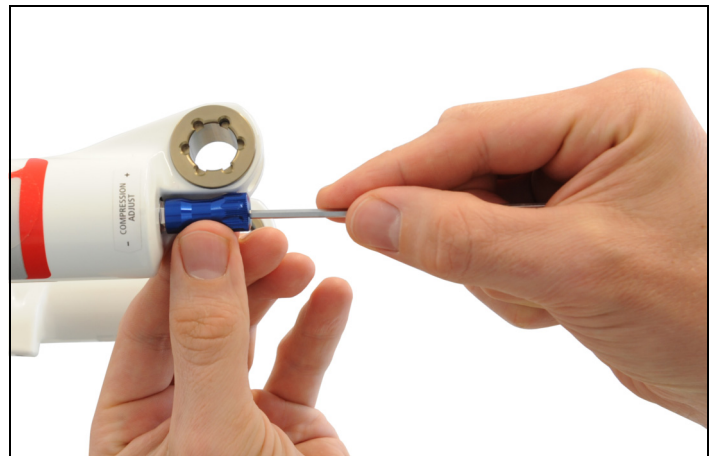

3. Remove the rebound adjuster pin.



4. Remove the adjuster lever using a 2 mm Allen key.



5. Remove the dial ring.



Disassembly of the Fork

1. Loosen the hexagon nut using a 8 mm socket wrench (or s.th. similar). Turn the nut approximately one turn.

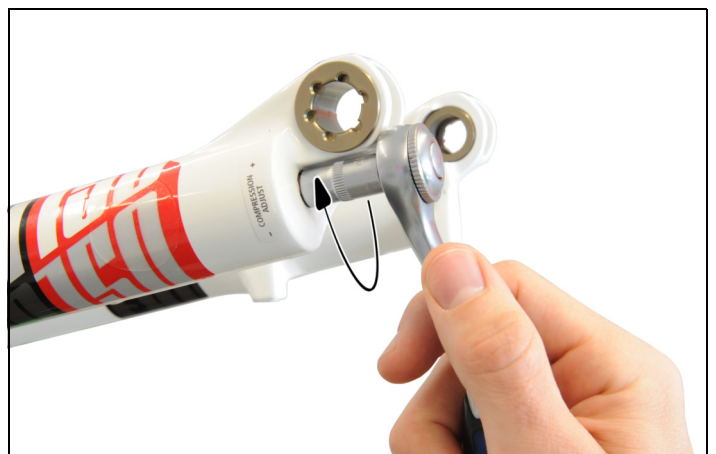

2. Unscrew the damping unit anti-clockwise using a face pin wrench.
 - Check if the damping unit will be unscrewed at the lower thread. If needed, turn the lower hex using a socket wrench (see last step).
 - Collect the leaking oil using a suitable container.

NOTE: There's a DT Swiss special tool available for unscrewing the damping unit. This can be used instead of the face pin wrench.



3. Remove the damping unit from the upper unit.
 - Collect the leaking oil using a suitable container.



4. Compress the damping unit a few times to release the entire oil.
 - Collect the leaking oil using a suitable container.

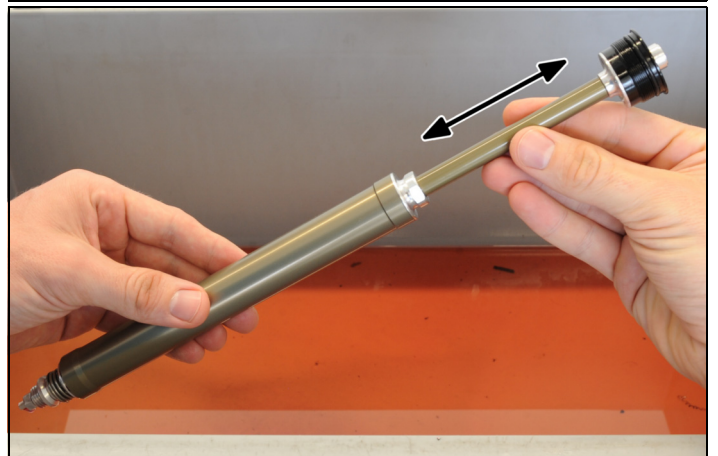

5. Fully screw in the hexagonal socket screw on the air side clockwise using a 4 mm Allen key.
 - Collect the leaking oil using a suitable container.



- 6.** Remove the lowers.
→Collect the leaking oil using a suitable container.

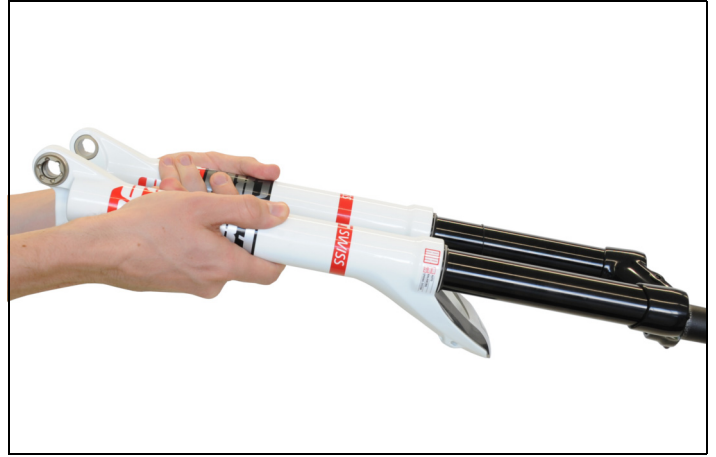

- 7.** Remove both spring rings from the main seals.



- 8.** Remove both foam rings below the main sealings.
9. Check the foam rings.
→Change the foam rings, if they are worn or badly soiled.
→If the main sealings are going to be changed, the foam rings can be changed additionally. The main seal kit includes main sealings and foam rings.



Dismount the Main Sealing



The main sealings don't have to be changed obligatory. If there are signs of wear, or if the stanchions are oily constantly, a change is recommended. There's a special tool needed for assembly!

1. Lever out the main sealing using a metal tire lever. Caution: The lowers must not be damaged. Remove the spring rings before dismounting the main sealings.



2. Remove the main sealings.



3. Remove the second main sealing in a similar manner.

Dismount the ABS Unit

1. Check, if the air is released (see [Release the Air, p.24](#)).
2. Remove the circlip using circlip pliers.
Caution: Do not scratch the piston rod!



3. Push the valve insert and remove the ABS unit.



Check and clean the Parts

1. Clean all parts:
 - Clean the inside and the outside of the lowers carefully.
 - Clean the inside and the outside of the uppers carefully.
 - Clean the ABS unit.
 - Clean the damping unit.
 - Clean the controls unit.
2. Check all parts for wear, deformation, damages etc.
3. If parts are damaged, contact a DT Swiss service center.

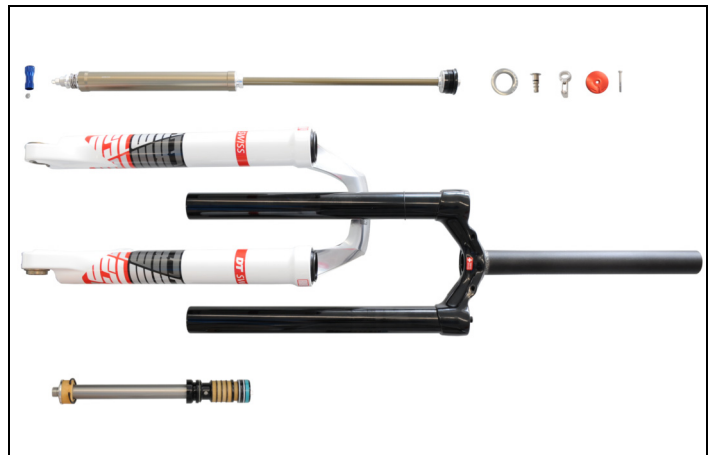

Mount the ABS Unit

1. Lubricate the elastomers and the sealings of the ABS unit with 3 ml DT Swiss Lube Fluid.



2. Press the valve insert and slide the ABS unit into the upper unit for about 7 cm.



3. Fill 2 ml DT Swiss Lube Fluid into the negative air chamber.



4. Slide the ABS unit into the upper unit completely.
5. Install the circlip using circlip pliers.
6. Check if the circlip is installed correctly.



Mount the Main Sealings



If the main sealings were not dismantled, the following chapter can be skipped. Next step: [Mount the lower Unit, p.33](#)

1. Degrease the seats of the main sealings and the main sealings.



2. Remove the spring rings from the main sealings.
3. Put on the main sealings.



4. Slide the tool into the first main sealing.



5. Carefully drive in the main sealing.
The main sealing must be flush with the upper edge of the lower unit.
6. Remove the tool from the main sealing.



7. Mount the second main sealing in a similar manner.

Mount the lower Unit

1. Soak the foam rings with DT Swiss Lube Fluid.
2. Put the foam rings between the bushings and the main sealings.



3. Slide both spring rings and the SAG o-ring onto the upper unit.



4. Slide the lower unit about 2 cm onto the upper unit.
 - Main sealings and foam rings must not be damaged.
 - Sliding on the lower unit must happen without big resistance.

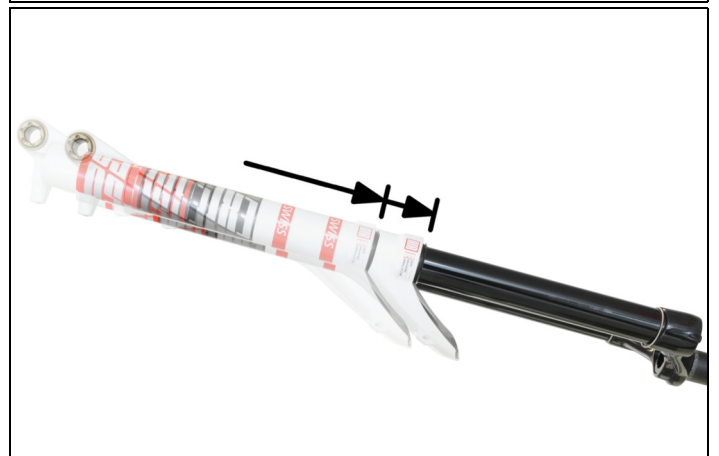

5. Fill 7 ml DT Swiss Fork Oil into the air side of the lower unit.
6. Fix the fork vertically for about 2 minutes to allow the bushings to be lubed.

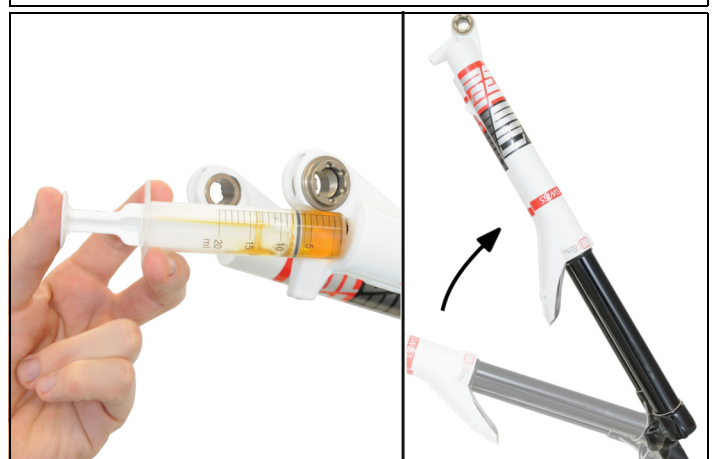

7. Slide the lower unit onto the upper unit completely.

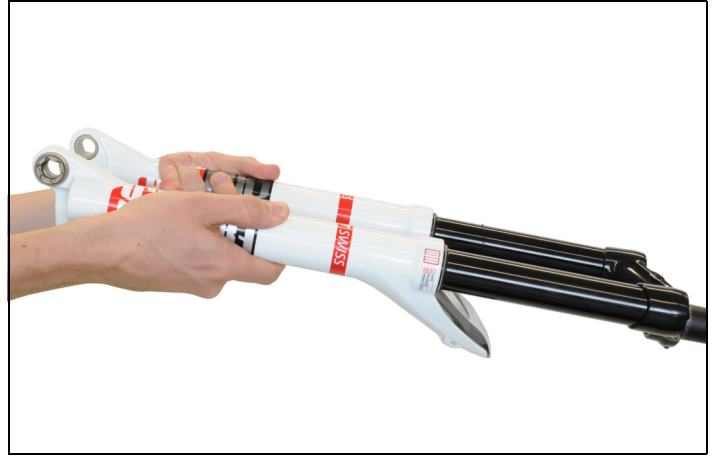

8. Screw the hexagonal socket screw on the air side into the lower unit anti clockwise using a 4 mm Allen key.

9. Tighten both hexagonal socket screws with a torque of 4 Nm.



10. Fully extend the damping unit.

11. Slightly compress the fork and slide the damping unit into the upper unit from the top.

12. Screw the lower thread of the damping unit into the lower unit.



13. Tighten the damping unit with a torque of 6 Nm using a socket wrench (or s.th. similar).



14. Fill in the damping oil stepwise.

- 130 mm travel: 140 ml DT Swiss Fork Oil
- 150 mm travel: 155 ml DT Swiss Fork Oil

15. To fill in the complete amount of oil, hold the upper unit and move the damping unit up and down.**16.** Tighten the damping unit with a torque of 10 Nm using a face pin wrench.

NOTE: There's a DT Swiss special tool available for tightening the damping unit. This can be used instead of the face pin wrench.

**17.** Slide both spring rings onto the main sealings.

Mount the control Elements

1. Put on the dial ring.
→The Launch Control indexation must face centered in drive direction.

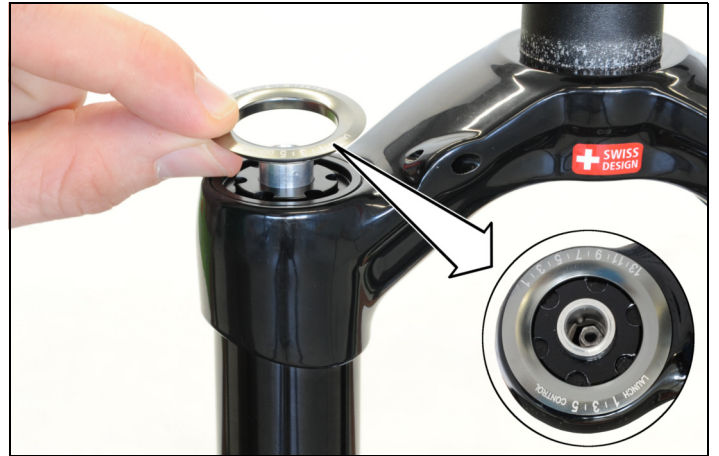

2. Mount the adjuster lever using a 2 mm Allen key.
→In position 3 the adjuster lever must face in drive direction.
→All five positions of the dial ring must be able to be reached by the lever.



3. Put in the rebound pin.
→If the rebound pin can not be inserted completely, turn it slightly using a 3 mm Allen key.



4. Mount the rebound wheel using a 2 mm Allen key.
→Align the rebound wheel, that the wheel is limited by the indexation 1 and 13 on the dial ring.

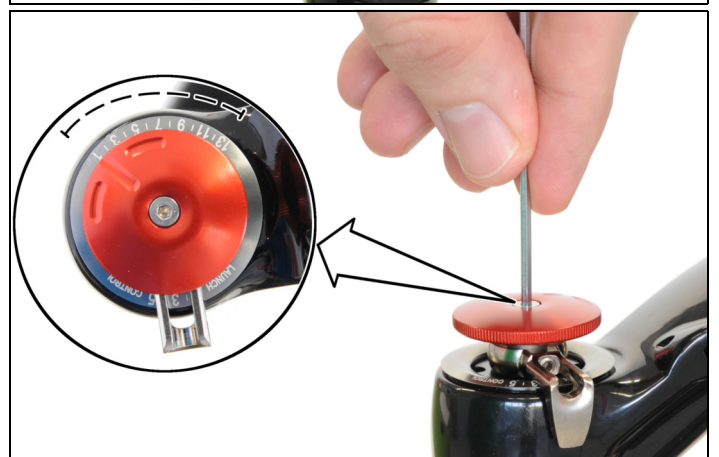

5. Mount the compression adjuster knob using a 2.5 mm Allen key.

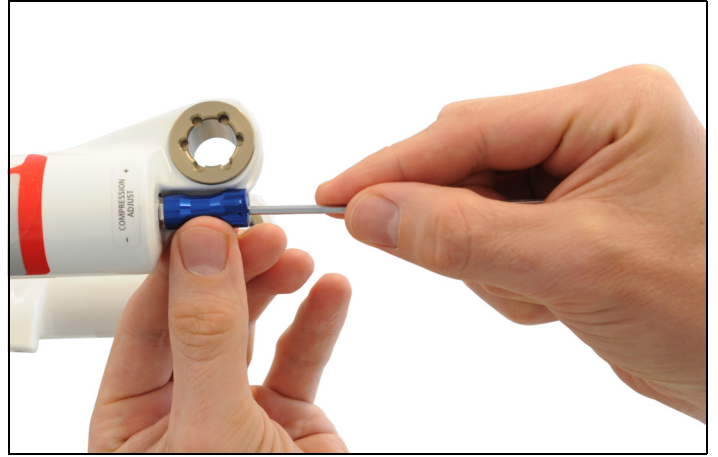

Closing Steps

Link

Dispose the oil in an environmentally compatible manner.

Inflate the fork.

[chap.4.1, p.18](#)

Check all functions of the fork.

The maintenance of the fork is complete. Enjoy the Ride!

6 Trouble Shooting



DANGER

Risk of injury due to a damaged fork!

If there are noticed damages or malfunctions, the fork must not be used!

- Contact a DT Swiss service center or your dealer to solve the problem.

Bedding-In Time

Some parts of the new fork may need some bedding-in or sagging-in time. Especially the bushings of a new fork may have a higher breakaway force. Therefore the fork may be uncomfortable. After about 20 hours of riding, the fork should be run in, and the effect will disappear.

After a Crash

After a crash the danger of damages is very high. Check your fork after each crash.

- Visual check: Check for damages such as cracks, breaks, oil leakages and scratches etc.
- Functional check: Check if all functions are working correctly.
- Acoustic check: Listen for unusual noises during slow riding or braking in a secure area.

Do not use a defective fork! Contact your local dealer or the responsible DT Swiss service center to repair the damage!

Bushing Clearance

DT Swiss forks use bushings in combination with oil lubrication. The function of the bushings is laid out for driving operation regarding an optimum of lubrication, thermal expansion of parts based on warming, manufacturing tolerances and the occurring loads. The bushing clearance is therefore necessary for the correct function of the fork and may be noticeable. A noticeable bushing clearance does not automatically mean an excessive wear out.

Trouble Shooting

Problem	Cause	Action
The fork is not responding properly.	The bedding-in time is not over.	Continue riding (bedding-in time is about 20 operating hours).
	The air pressure is too high.	Decrease the air pressure controlled using a suitable shock pump.
	The fork needs a small service.	Carry out a small service (see chap.5.3, p.23) yourself or by your dealer or a DT Swiss service center.
The fork bottoms out on moderate bumps.	The air pressure is too low.	Increase the air pressure controlled using a suitable shock pump.
The fork does not rebound completely and hardens on fast repetitive bumps.	Too much rebound damping.	Decrease rebound damping.
The fork rebounds too fast, the front wheel loses contact to the ground after bumps or it slides in turns.	Not enough rebound damping.	Increase rebound damping.

Problem	Cause	Action
Air Spring		
The fork becomes compressed while decreasing the air pressure.	Too fast decreasing of the air pressure.	Increase the air pressure controlled using a suitable shock pump until achieving the initial air pressure or pull the fork manually apart and hold it a short time pressed against the top out. Then decrease the air pressure controlled using a suitable shock pump.
Damping		
The lockout does not work well.	Leaks inside the cartridge.	Contact your local dealer or the responsible DT Swiss service center to solve this problem.
	Remote Lockout: The lockout cable is not tensioned correctly.	Check the proper fixation and the tension of the lockout cable.

DT Swiss AG

Längfeldweg 101

CH - 2504 Biel/Bienne

E-mail: mail@dtswiss.com

DT Swiss, Inc.

2493 Industrial Blvd.

USA - Grand Junction, CO 81505

E-mail: info@dtswiss-us.com

DT Swiss (France) S.A.S.

Parc d'Activites de la SARREE

Route de Gourdon

F - 06620 Le Bar sur Loup

E-Mail: service.fr@dtswiss.com

DT Swiss (Asia) Ltd.

No. 26, 21st Road Industrial Park

Taichung City

E-mail: info@dtswiss-asia.com

www.dtswiss.com

Subject to technical alterations, errors and misprints excepted. All rights reserved.

© by DT Swiss AG